

Mapping of bridge pier scour with projection moiré

Relevé des affouillements au droit des piles de pont par projection Moiré

GERALD MÜLLER, *Lecturer, Queen's University Belfast, Civil Engineering Department, David Keir Bldg., Stranmillis Rd., Belfast BT7 5AD, UK, Tel.: +49 1232 274517, Fax: +49 1232 663754, email: g.muller@qub.ac.uk*

RÜDIGER MACH, *Project Engineer, Bundesanstalt für Wasserbau, Karlsruhe, Germany*

KLEMENS KAUPPERT, *Project Engineer, Bundesanstalt für Wasserbau, Karlsruhe, Germany*

ABSTRACT

During the construction works for an extension of an existing bridge pier severe scouring occurred after the placement of a sheet pile cofferdam. A detailed investigation of the situation was conducted at the *Bundesanstalt für Wasserbau* (Federal Hydraulic Research Institute) in Karlsruhe, Germany. For the measurement of the scour development without protective layer, an optical measurement method - out-of-plane projection Moiré - was employed in order to investigate its suitability. This technique uses the Moiré effect to map surface contours which are indicated by superposition lines or fringes. The Moiré fringe patterns generated by the measurements were then digitised for further analysis. The contour model revealed that, although the scouring depth did not increase significantly with time after the initial scour had formed, scour size did in fact do so. In addition, the contour model allows to map the scour extension and to determine the maximum deposition height. A 3D model of bridge pier and scour showed, in combination with photographs, the validity of the measurement technique and pointed towards the generation of a virtual environment for the representation of experimental results.

RÉSUMÉ

Lors des travaux d'extension d'une pile de pont existante, la mise en place d'un batardeau entraîne un affouillement important. Une investigation détaillée de la situation a été menée au *Bundesanstalt für Wasserbau* (Federal Hydraulic Research Institute) à Karlsruhe en Allemagne. Une méthode de mesure optique – la projection Moiré hors plan – a été employée pour mesurer l'évolution de l'affouillement sans couche protectrice, afin d'en tester la pertinence. Cette technique utilise l'effet Moiré pour cartographier les courbes de niveau qui sont indiquées par des lignes de superposition ou des franges. Les tracés de franges de Moiré générés par les mesures ont été numérisés pour être analysés. La modélisation des courbes de niveau a révélé que, malgré un accroissement peu significatif de la profondeur de l'affouillement après la phase de formation initiale, la taille de celui-ci s'est en réalité accrue. De plus, la modélisation des courbes de niveau permet de faire un relevé de l'extension de l'affouillement et de déterminer la hauteur maximum de dépôt. Un modèle 3D de la pile de pont et de l'affouillement, associé aux photographies, a permis de montrer la validité de la technique de mesure et ouvre la voie vers la génération d'un environnement virtuel pour la représentation de résultats expérimentaux.

Introduction

The construction of new urban railway lines required the extension of an existing bridge across the River Rhine in Mannheim, Germany. One additional track had to be added to the existing railway line, and it was decided to lengthen the existing bridge piers to support the new line. The upstream extension of the bridge piers was planned employing the same geometry as the old pier. Fig. 1 shows the geometry of the bridge pier. After placement of the sheet piles, which were intended to serve as cofferdam and permanent shutter for the pier, deep erosion scours appeared immediately at the left and right upstream corner of the pier. Although this was partly blamed on the loosening of the ground for the preceding munitions search, it was decided to investigate the problem at the *Bundesanstalt für Wasserbau* (Federal Institute for Hydraulic Research) in Karlsruhe/Germany to identify the scope and a solution for the erosion problem. During this investigation, tests were conducted to assess the final scour size as well as tests to determine adequate scour protection layers. Within these test series, it was decided to employ a new optical measurement technique, out-of-plane projection Moiré, to map the scours for the unprotected case. In the following, the experiment and this measurement technique are described, results are presented and the use of up-to-date graphic software to illustrate

the experimental results is demonstrated.

Mapping techniques

On many occasions it is desirable to map the erosion surface within a hydraulic model test e.g. to measure the displaced volume. There are a number of mapping techniques for scour tests in hydraulic modelling available: wool threads, depth pointers, photogrammetry, and projection Moiré.

Woolen threads: contour mapping with wool threads is an old technique. After the scouring test is finished, the tank is slowly emptied. Once the water level reaches say 10mm below the original surface, a wool thread is laid along the contour of the water table. Then, the water level is lowered another 10mm etc. Finally, a photograph of the contour lines is taken.

Depth pointer gauges: One or a series of pointer gauge scales are fixed to a mounting across the scour. The needle is lowered until it touches the ground. A measurement is taken and the needle is moved forward to the next position. The technique can be operated manually (particularly for very light sediment such as lignite) or automatically.

Photogrammetry: This technique has experienced enormous progress. There are systems available to map surfaces which do not require marker points on the measurement plane - they work

Revision received November 21, 2000. Open for discussion till April 30, 2002.

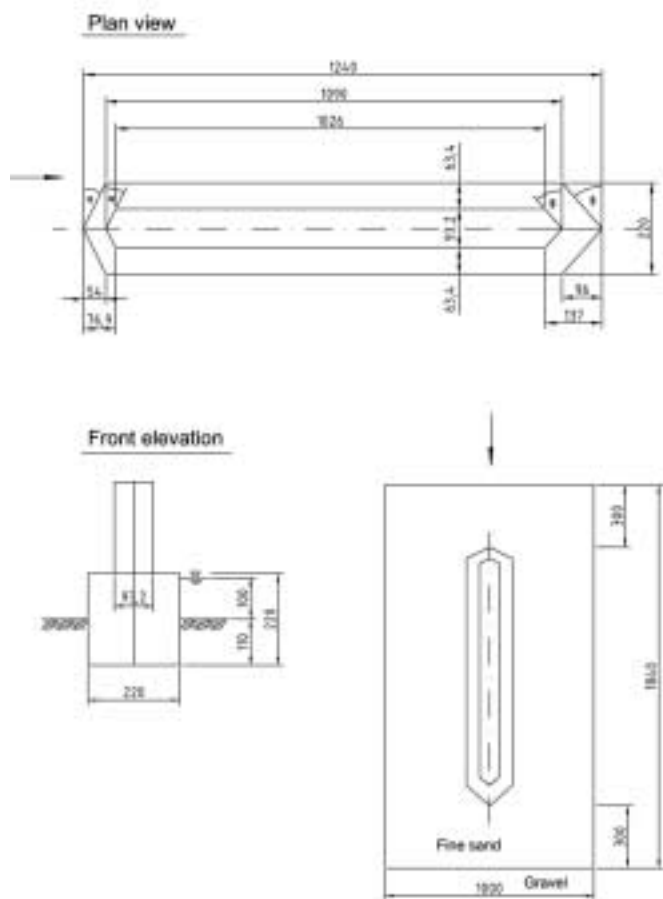

Fig. 1 1:80 model of bridge pier with planned extension

by projecting a grid with a marked starting point onto a disturbed surface. Digital pictures of this grid are then taken by both cameras. After manual identification of a starting point, the appropriate software identifies each line crossing of the grid as a measurement point and creates a digital map of the surface.

Projection Moiré : a technique which is frequently employed in mechanical engineering and in medicine to measure surface distortions or curvatures. A line grid is projected vertically onto an undisturbed reference plane and a photograph is taken with an inclined camera. The grid is again projected onto the disturbed or deflected surface and another photograph is taken. Both photographs are then superimposed. The superposition picture shows a set of dark and bright or Moiré lines, which constitute lines of equal elevation, whereby the height difference between the contour lines is a function of the geometry of the experimental set-up. This technique can also be used with an inclined projector and a vertical camera.

Projection Moiré is extensively used in mechanical engineering and in medicine, e.g. Sciammarella (1982). In Civil Engineering, a variation of the technique, which employed a stationary and rather complex set-up, was used to measure the curvature of slab models, Ligtenberg (1955). This technique does however require the deflected surface to mirror the line grid (e.g. by employing polished stainless steel for the model) and is thus not suitable for hydraulic engineering problems. To the authors' knowledge, out-of plane Moiré has not been employed in hydraulic modelling although it offers an efficient and cost-effective alternative to

other mapping techniques.

One common disadvantage of all the techniques presented is that the actual measurement requires a drained tank. The wool thread technique is very laborious, time consuming and not very accurate. Measurements with depth pointers require a complicated mechanical set-up. They are also time consuming, since they measure point by point, and do not work well with very fine or light sediment material. Optical techniques such as photogrammetry and projection Moiré measure the whole surface in one instant, whereby the type of the sediment is of no importance as long as the contrast provided is sufficient. These methods could in principle be used to measure under water as well, but usually scouring experiments involve fast, possibly supercritical flow and disturbed water surfaces, which make this impossible. Photogrammetry in principle offers a very elegant solution as an optical measurement method. Its disadvantages are the high cost of the system, the requirement for two cameras and a fixed mounting, complicated calibration procedures and difficult contrasts provided by the irregular surfaces of wet sand or gravel. In addition, the measurement system can not measure over obstacles (it requires all points to be in view from both cameras) and it requires continuous surfaces. In particular the last two points made photogrammetry not suitable for the bridge pier scour measurements. Within the test program, it was thus decided to test the suitability of projection Moiré for the mapping of the scour with the intention to use the data set generated for further analysis and for presentation purposes.

The projection moiré technique

Projection Moiré only requires a projector and a camera, which can be mounted easily in most situations. The projector projects a set of grid lines on the measurement plane as shown in Fig. 2a. The camera angle η has to be chosen so that all surfaces can be photographed. By adding reference points with known co-ordinates the distortion resulting from the camera angle can later be removed. The projector angle β can be chosen at will; in order to avoid a distortion of the grid however an angle of 90 degrees is recommendable. In Fig. 2a, 'd' denotes the horizontal distance between the optical axis of camera and projector, 'g' the grating pitch of the projected grid, and 'w' the surface distortion at a chosen point.

The geometry of the disturbed surface means that, after superposition of the two photographs, in some areas the dark lines of one picture move into the bright lines of the other picture creating dark lines, as indicated in Fig. 2b. In other areas, the two projected lines lie on top of each other without interference. The Moiré fringes – i.e. the dark lines created by the superposition - indicate lines of equal elevation above (or below) the reference plane. The elevation itself is a function of the geometry of the set-up and of the line density. The projector has to be regarded as a point source of light and the appropriate formula for the calculation of the depth w of a fringe line becomes:

$$w = \frac{\delta_s g}{\frac{d}{l} - \frac{\delta_s g}{l}} \quad (1)$$

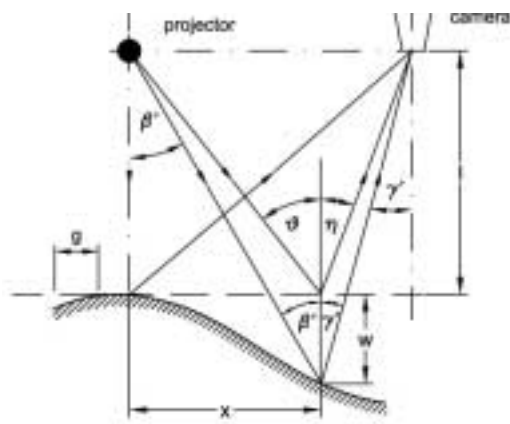

a. Camera and projector set-up

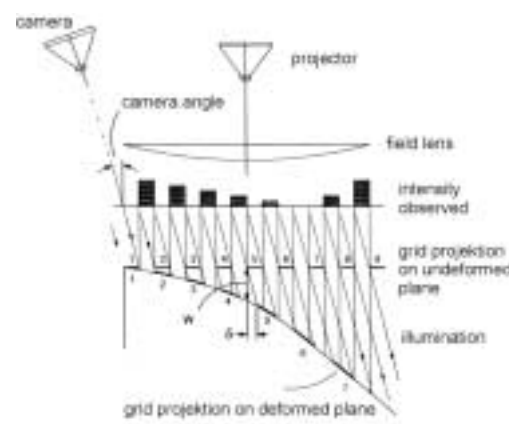

b. Out-of-plane Moiré

Fig. 2 Projection Moiré

where: w : elevation of contour line

δ_s : order number of Moiré line (only the bright lines are counted)

g : distance between two grid lines on the measurement plane

d : distance between camera and projector

l : distance between camera/projector and measurement plane

The technique is described in most textbooks on experimental stress analysis, e.g. Rohrbach (1989). Eq. (1) allows to calculate an elevation for every interference line of the Moiré pattern. It should be noted that the distance between the lines increases with increasing order number δ_s of the line. Although the pictures have to be processed later, the availability of the equipment, the easy set-up and the fact that all measurable points have to be seen by one camera only makes projection Moiré an easy measurement method for surface distortions for a hydraulic laboratory.

One disadvantage of the Moiré fringe pattern is that the pattern itself does not give any information about the order of an individual line. The fringe order has to be determined during the digitisation. Although the order number at the scour surface is quite clear, the deposition areas can provide difficulties in this respect. In order to help interpretation of the line pattern additional photographs from different angles had been taken from the scoured surface after the test was finished.

Scour measurement

General

The scour measurements were conducted at a 1:80 model of the bridge pier as shown in Fig. 1. The tests were conducted in order to identify the maximum extension and depth of the pier scour, and to evaluate the volume required for filling it in. For this purpose, it was decided to use a non-intrusive mapping technique in combination with modern image processing software, which allows to analyse the digitised data from the measurement itself. In addition, it was decided to create 3D images of the scour for pre-

sentation as well as for verification purposes.

Experimental set-up

The experimental set-up consisted of the constant flow flume with the model in it, the camera and the projector. The flume, located in the *Bundesanstalt für Wasserbau* in Karlsruhe/Germany, had a length of 20.00 m, a width of 2.00 m and a water depth of 100mm. The water depth was regulated with a weir at the end of the tank and checked with a depth point gauge at the position of the bridge pier model. The bridge pier model, as shown in Fig. 1, was made of concrete and fixed immovably in the tank. An area of 1000 × 1800 mm around the bridge pier was filled with fine sand of $d_{50} = 0.5\text{mm}$, the rest of the tank was filled with gravel of $d_{50} = 10\text{mm}$ which remained stationary during the experiment. The flow volume for all tests was determined as 42.4 l/s at 100mm water depth, corresponding to 0.21 m/s and simulating an average high water of the River Rhine at the respective location. Three tests were conducted with 35, 60 and 120 minutes duration to map the development of the scour. Fig. 3 shows the set-up with camera and projector.

The distances between camera, projector and measurement plain varied between the experiments, since it is not required to have exactly the same positions for projector and camera, and since e.g. the scour for test 3 was found to be deeper and larger so that a larger measurement area was required. Table 1 gives the distances d , and l for all tests as well as g , the distance between two grid lines on the measurement plane (determined by measuring the distance for 50 lines):

Table 1 Parameters for tests 1–3

Test nr.	d (mm)	l (mm)	g (mm / line)
1	1320	580	4.65
2	1320	560	4.65
3	1505	620	5.26

The projector (and camera) distance for test 3 was increased in order to capture the full field of erosion. In the projector, a 55 ×

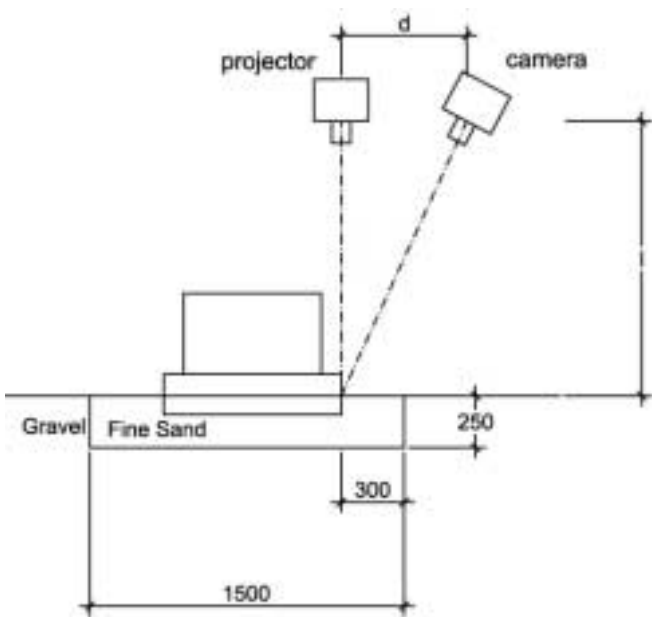

Fig. 3 Side elevation of experimental set-up

60 mm slide with 5 lines per mm was inserted. The camera used was a digital Nikon E3 with 1280×1000 pixel picture size and a 70mm zoom lens.

10 reference points with known co-ordinates were placed onto the undisturbed surface. These points, made up out of 5mm diameter styrofoam buttons, were later washed away by the flow. All three tests were conducted starting with a photograph of the undisturbed surface (with reference points) and finishing after the pre-determined stopping time. The tank was then drained carefully and a second photograph was taken. The assumption was that the scouring develops continuously, so that the tests are representative of different stages of scouring of one test.

Experimental results

The experimental results consisted of three pairs of photographs plus additional side views of the scours. The side views were



a. Undisturbed picture with reference points



b. Scour picture

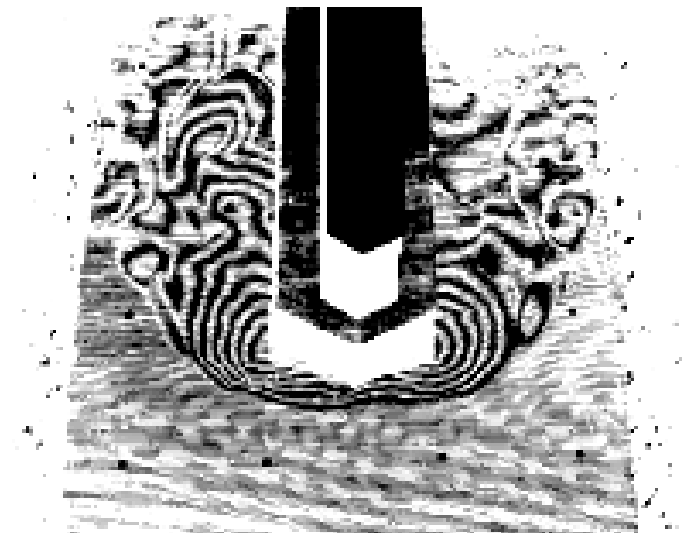

c. Superposition of a and b gives the Moiré fringe pattern

Fig. 3 Photographs and superposition

taken to have additional information for the interpretation of the Moiré fringe pattern. For each test, the picture pairs were contrast enhanced and then superimposed. Fig. 3 shows the original pictures and the superposition for test 3, $T = 120$ Minutes.

The superposition picture was again contrast enhanced; a procedure which included cutting and inverting to make the fringes very visible. The same procedure was used on the other two picture pairs. Fig. 4 shows the fringe patterns for test series 1 – 3: The Moiré fringe patterns indicate lines of equal height, i.e. contour lines, which map the scour at the front of the bridge pier as well as the deposition area behind it. Unfortunately, the projector had to be placed with its optical axis at the front corner of the pier in order to map the area in front of the model. This, in combination with the quality loss of the projection towards the corners (probably caused by the projectors' lens system) meant that the full length of the deposition area could not be covered. The numerical evaluation of the experiment with eq. 1 is shown in table 2, which gives elevations for fringe orders 1,3 and 5 for tests 1-3.

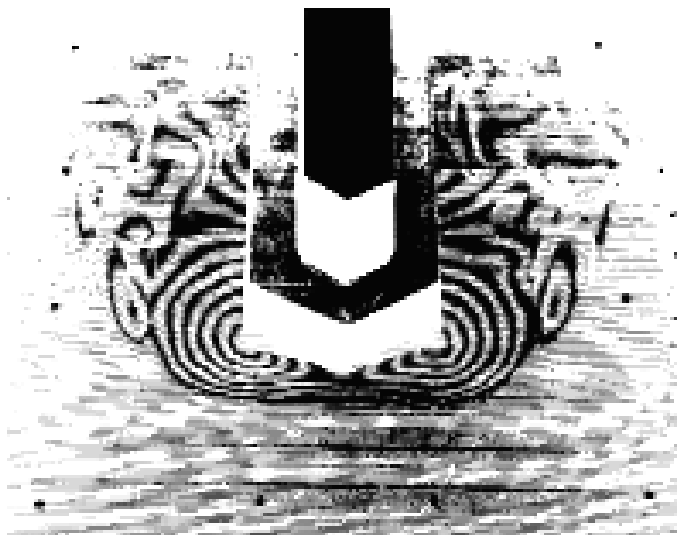

a. Test 1, T = 35 min.

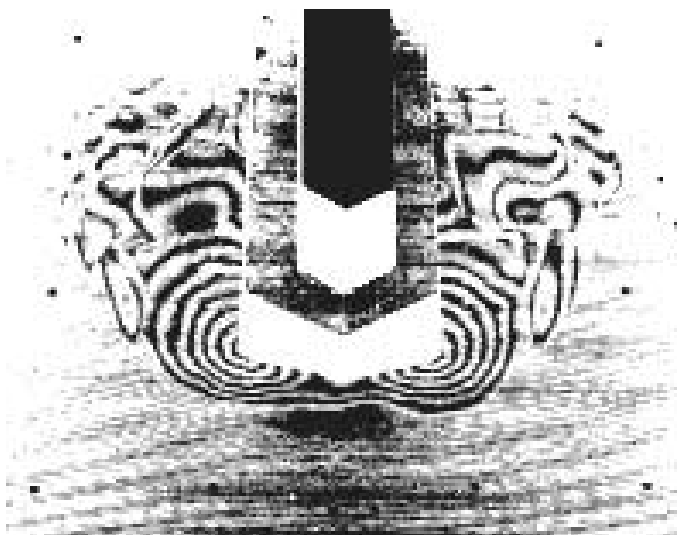

b. Test 2, T = 60 min.

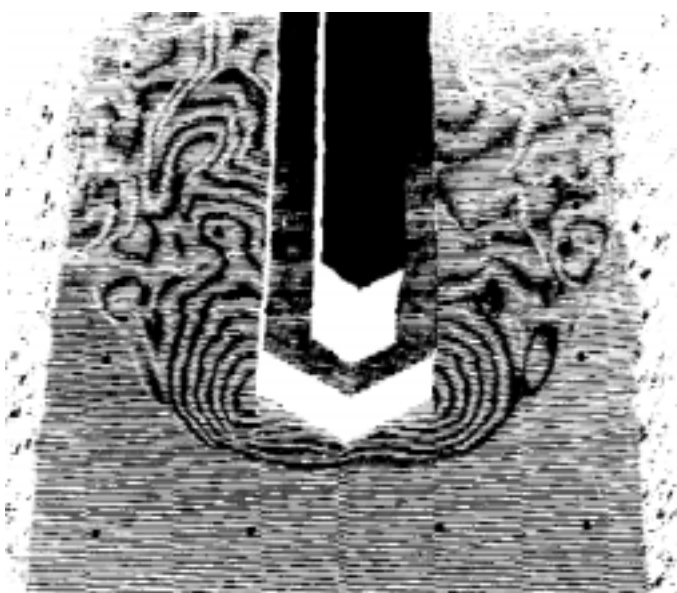

c. Test 3, T = 120 min

Fig. 4 Moiré fringe patterns from tests 1 – 3, perspective distortion removed

Table 2 Elevation (mm) for fringe numbers 1,3,5

Test Nr.	1	2	3
Fringe 1	10.5	10.9	12.7
Fringe 2	31.0	32.1	37.4
Fringe 3	50.9	52.6	61.2

The Moiré technique could not measure accurately the very deepest point of the scour at the front corner of the bridge pier. For such small areas the superposition effect is simply not visible. In table 3, the values measured for the deepest point d_m (using a colour coded scale fixed to the model) and the values from the fringe pattern $d_{Moiré}$ are shown:

Table 3 Maximum scour depths (mm)

Test	d_m	$d_{Moiré}$
1	65	56
2	70	63
3	85	84

From table 3 it can be seen that the accuracy increases with increasing depth and size of the scour, as would be expected. The maximum accuracy of the Moiré technique depends on the distance between the projected fringe lines. Fig. 2b shows that a new black or white line only forms whenever a line on the disturbed surface moves between (or underneath) the reference line. The accuracy of the experiments described in here is within 0.5 of the fringe distance, i.e. between 5-6mm, so that the results from these tests can be considered satisfactorily. The grid line distance or line thickness was in this experiment a function of the limitations of the camera; 2-3 pixels per line thickness were considered essential for a proper image. The projection slide was generated with an accuracy of 1200 dpi, so that an additional maximum error of 1 pixel/line or +/- 0.5mm on the reference plane can be expected. This error is however not accumulative, and thus small compared with the errors discussed before.

Graphic data processing

Principle

From the beginning, the intention of the group was to produce a digital surface data of the Moiré pictures, which can then be used further to create contour lines as well as digital surface maps and to conduct a volumetric analysis of the sediment movement. The Moiré line pattern had to be analysed in four steps:

- removal of geometric distortion.
- Digitisation of contour lines.
- Construction of digital 3D model.
- Plot of contour lines and 3D surface views.

Initially, the geometric distortion was removed using MicroStation based on the co-ordinates of 10 reference points of known co-ordinates in the picture, see Fig. 4. The Moiré line pattern was then digitised in AutoCad, whereby each level was retained on a different layer. This data set forms the basis for two different

types of visualisation, namely the plotting of contour lines and the generation of a 3D surface.

Contour lines

These lines were determined from the layered AutoCad files in order to produce a data set, which can then be analysed by other programs e.g. to create cross sections or volume calculations. Fig. 5 shows the contour plot for tests 1. Here, the 5mm equidistant contour lines are shown – the 5mm were chosen to get more details of the surface contour without having too many lines, which would obscure the picture.

The development of a set of equidistant lines from the Moiré pattern is easily done with modern graphics packages and allows to overcome the fact that the height difference between two consecutive fringe lines in the Moiré picture increases with increasing order number. The computer generated contour lines of a scour will allow:

- To assess the displacement and deposition volume
- To estimate of the maximum height of the deposition.
- The generation of cross-sections and longitudinal sections.
- The determination of the scour size and damage potential.
- The assessment of a scouring after a protection has been built.

The generation of contour lines thus enables the hydraulic modeller to measure the geometry of a scour (and/or its development) with higher accuracy and less experimental effort than previous methods. In addition, the Moiré technique can be employed for all types of materials provided it can generate sufficient contrast for the lines to be visible.

3D surface generation

It was decided to perform a 3D visualisation of the distorted surface in order to check the accuracy of the method, to assess whether or not the order numbers of the fringes were assigned correctly and to create a visualisation for detailed comparison of scour development and for presentation purposes. In the first step, the data was imported into the visualisation package 3D Studio Viz (Kinetics / Discrete) and used to form a digital surface. The bridge pier was then fixed in space by giving it co-ordinates within the reference point system of the measurement and attached to the surface. In the third step, a side view of the scour –

as shown in Fig. 6a - was laid behind the digital surface, whereby several points on the bridge pier were employed as reference points to calculate the position of the virtual camera. With this information, the triangulation mesh could be laid over the photograph, as shown in Fig. 6b.

Initially, it was found that two line sets had been numbered incorrectly. The correction could be performed in the original data set, and was automatically implemented into the 3D visualisation. Mesh and photograph matched well, indicating the accuracy of the Moiré technique. Finally, the surface was textured and smoothed into the photograph to create a 3D model of the scour as shown in the side view in Fig. 6c.

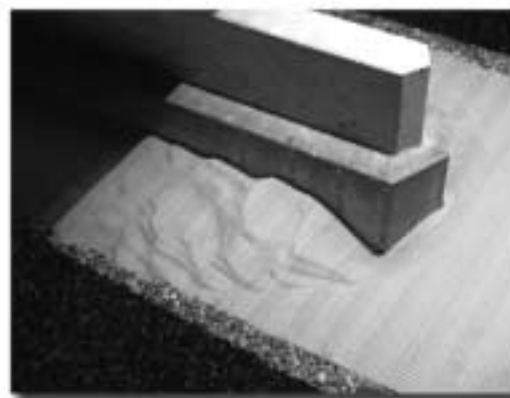

a. Side view of bridge pier scour, T = 35 min



b. Triangulation mesh overlaid with side view

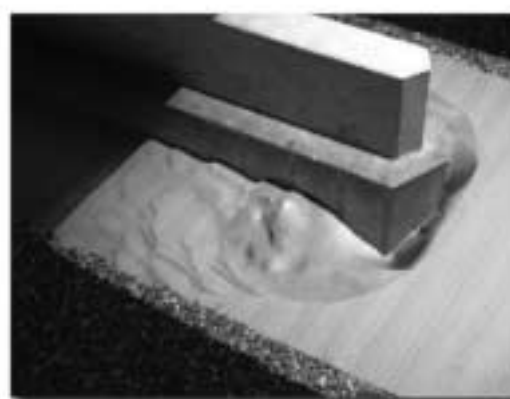

c. 3D surface from measurements overlaid with side view

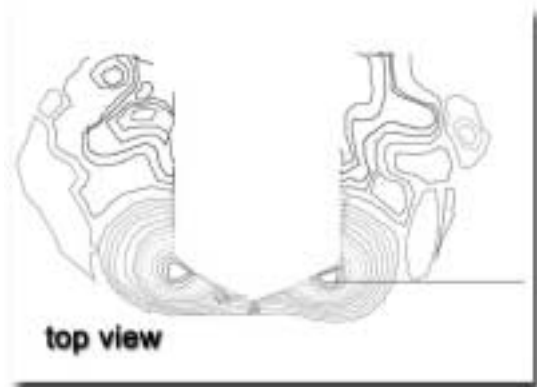

Fig. 5 Contour lines for test 1

Fig. 6 3D Visualisation of experimental data

Discussion

Within an assessment of bridge pier scour at a railway bridge across the river Rhine, the projection Moiré technique was employed to map the contours of a bridge pier scour in order to assess its applicability to scouring problems in hydraulic model testing. To the author's knowledge, the Moiré technique was so far never used to map erosion scours, and was only very infrequently employed in other civil engineering applications. One reason for this could be that, with the model sizes employed in civil engineering it is difficult to obtain collimated light sources. With point sources the distance between two individual Moiré lines increases with increasing order number, which makes the manual analysis of the pictures very difficult. Modern graphics software has however overcome this problem, and projection Moiré can now easily be used for mapping purposes. In combination with modern graphics packages, contour lines and a 3D model of the scour could be generated and used for further analysis, e.g. to measure volume displacements. The Moiré technique provided an excellent non-intrusive measurement technique for surface distortions. Its two disadvantages are the requirement for manual digitisation (this simply means that the Moiré lines are re-drawn and layered, although the actual line trace occasionally does require some interpretation), and the ambiguity of the lines with respect to the order number.

This technique has the particular advantages of low costs (the large height differences e.g. of scours mean that even the slide with the grid lines can be made by many printing companies), and of a comparatively easy experimental set-up. The set of contour lines generated from the Moiré traces can then be employed e.g. for the volumetric analysis of the erosion process. Modern graphics software allows viewing the digital model from all angles, inserting the computer generated surface into other pictures etc. The good match of the digital surface with the photograph of the scour indicated the validity of the technique as well as the possibilities offered by modern graphic software.

The digital models can then be further utilised e.g. for the validation of computer simulations of erosion processes or for presentation purposes. In particular the latter area appears to be very promising since changes measured in the model tests could actually be scaled up and inserted into pictures of a real geometry, allowing to assess their impact on the situation considered and to

present the results to the public. The generation of mixed and/or virtual environments employing the results of physical model tests for the purposes mentioned is possible using a combination of image based measurement technology and modern software.

Conclusions

The erosion occurring during construction works at the pier of a railway bridge across the River Rhine led to a detailed investigation of the scouring employing physical model tests. Within this investigation, the applicability of the projection Moiré technique for mapping of the development of the scour without protective layer was investigated. It was found that this technique, which had previously never been used in hydraulic modelling, worked very well. The results from the measurements could be digitised easily, and that they could be further processed with modern graphics software now available. The software allowed the generation of contour plots, the analysis of the scour area and the maximum height of deposition. The 3D software was then employed to generate 3D models of the situation, which matched actual photographs well, further indicating the validity of the measurements. The combination of a new application of an optical area measurement technique with up-to-date graphics software allowed the rapid analysis of a scouring problem and the creation of 3D images for a virtual environment.

Acknowledgements

The authors would like to express their gratitude towards the *Bundesanstalt für Wasserbau* and the *Royal Academy of Engineering* for their kind support of this research project.

References

- F.K. LIGTENBERG, The moiré method, a new experimental method for the determination of moments in small slab models, *Proc. Soc. Exp. Stress Analysis.*, 1955, Vol. 12, No. 2, 83-98
- C. ROHRBACH (Ed.), *Handbuch für experimentelle Spannungsanalyse* (Handbook for experimental stress analysis), 1989, VDI Verlag, Düsseldorf (Germany)
- C.A. SCIAMMARELLA, 1982, The Moiré method – a review, *Experimental Mechanics*, 418-433